

# Determination of Chloride Ion Concentration by Titration (Mohr's Method)

## Introduction

This method determines the chloride ion concentration of a solution by titration with silver nitrate. As the silver nitrate solution is slowly added, a precipitate of silver chloride forms.

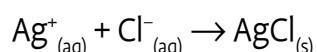

The end point of the titration occurs when all the chloride ions are precipitated. Then additional chloride ions react with the chromate ions of the indicator, potassium chromate, to form a red-brown precipitate of silver chromate.

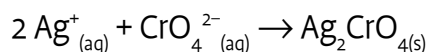

This method can be used to determine the chloride ion concentration of water samples from many sources such as seawater, stream water, river water and estuary water. Seawater is used as the example here.

The pH of the sample solutions should be between 6.5 and 10. (Refer to the additional notes (3) for the explanation). If the solutions are acidic, the gravimetric method or Volhard's method should be used.

## Equipment Needed

- burette and stand
- 10 and 20 mL pipettes
- 100 mL volumetric flask
- 250 mL conical flasks
- 10 mL and 100 mL measuring cylinders

## Solutions Needed

**Silver nitrate solution:** (0.1 mol L<sup>-1</sup>) If possible, dry 5 g of AgNO<sub>3</sub> for 2 hours at 100°C and allow to cool. Accurately weigh about 4.25 g of solid AgNO<sub>3</sub> and dissolve it in 250 mL of distilled water in a conical flask. Store the solution in a brown bottle.

**Potassium chromate indicator solution:** (approximately 0.25 mol L<sup>-1</sup>) Dissolve 1 g of K<sub>2</sub>CrO<sub>4</sub> dissolved in 20 mL distilled water)

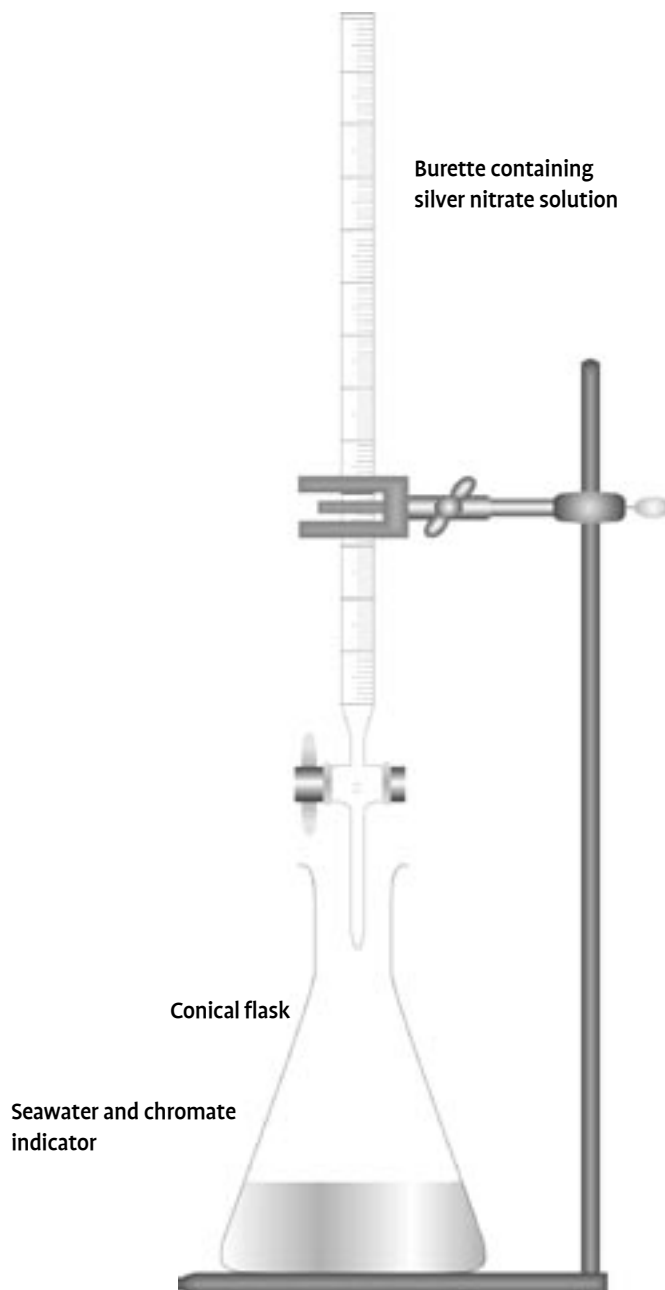

## Method

### Sample Preparation

If the seawater contains traces of solid matter such as sand or seaweed, it must be filtered before use. Otherwise they will end up being weighed along with the silver chloride precipitate.

### Titration

1. Dilute seawater by pipetting a 20 mL sample into a 100 mL volumetric flask and making it up to the mark with distilled water.
2. Pipette a 10 mL aliquot of diluted seawater into a conical flask and add about 50 mL distilled water and 1 mL of chromate indicator.
3. Titrate the sample with 0.1 mol L<sup>-1</sup> silver nitrate solution. Although the silver chloride that forms is a white precipitate, the chromate indicator initially gives the cloudy solution a faint lemon-yellow colour (figure 1). The endpoint of the titration is identified as the first appearance of a red-brown colour of silver chromate (figure 2).
4. Repeat the titration with further aliquots of diluted seawater until concordant results (titres agreeing within 0.1 mL) are obtained.



**Figure 1** Before the addition of any silver nitrate the chromate indicator gives the clear solution a lemon-yellow colour.

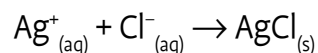

**Figure 2** Left flask: before the titration endpoint, addition of Ag<sup>+</sup> ions leads to formation of silver chloride precipitate, making the solution cloudy. The chromate indicator gives a faint lemon-yellow colour. Centre flask: at the endpoint, all the Cl<sup>-</sup> ions have precipitated. The slightest excess of Ag<sup>+</sup> precipitates with the chromate indicator giving a slight red-brown colouration. Right flask: If addition of Ag<sup>+</sup> is continued past the endpoint, further silver chromate precipitate is formed

and a stronger red-brown colour results. NB: The titration should be stopped when the first trace of red-brown colour is observed. Using an incompletely titrated reference flask for comparison is a helpful way to identify the first appearance of red-brown colouration.

## Result Calculations

1. Determine the average volume of silver nitrate used from your concordant titres.
2. Calculate the moles of silver nitrate reacting.
3. Use the following reaction equation to determine the moles of chloride ions reacting.



4. Calculate the concentration of chloride ions in the diluted seawater.
5. Calculate the concentration of chloride ions in the original undiluted seawater.
6. Calculate the concentration of sodium chloride in the seawater in molL<sup>-1</sup>, gL<sup>-1</sup> and g/100 mL (%).

## Additional Notes

1. Silver nitrate solution will stain clothes and skin. Any spills should be rinsed with water immediately.
2. Residues containing silver ions are usually saved for later recovery of silver metal. Check this with your teacher.
3. The Mohr titration should be carried out under conditions of pH 6.5 – 9. At higher pH silver ions may be removed by precipitation with hydroxide ions, and at low pH chromate ions may be removed by an acid-base reaction to form hydrogen chromate ions or dichromate ions, affecting the accuracy of the end point.
4. It is a good idea to first carry out a “rough” titration in order to become familiar with the colour change at the end point.
5. The Mohr titration is sensitive to the presence of both chloride and bromide ions in solution and will not be too accurate when there is a significant concentration of bromide present as well as the chloride. However, in most cases, such as seawater, the bromide concentration will be negligible. For this reason, the method can also be used to determine either the total concentration of chloride and bromide in solution, or the concentration of bromide when the chloride concentration is known to be negligible.